

NOT ENOUGH METAL LEFT FOR SUPPORT

REMOVING SPINDLE FACE STEP
AND MOVING COLLET DEEPER
MAKES OTHER PROBLEMS WORSE

TAPER INTERSECTS PIN HOLE

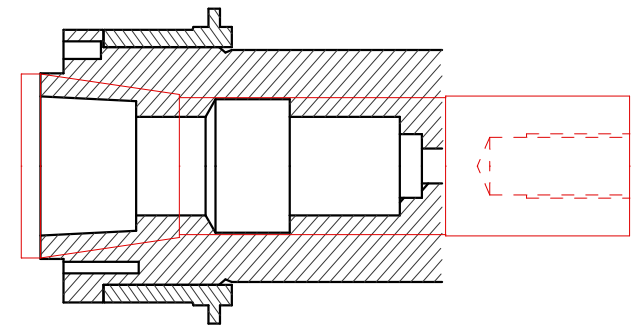
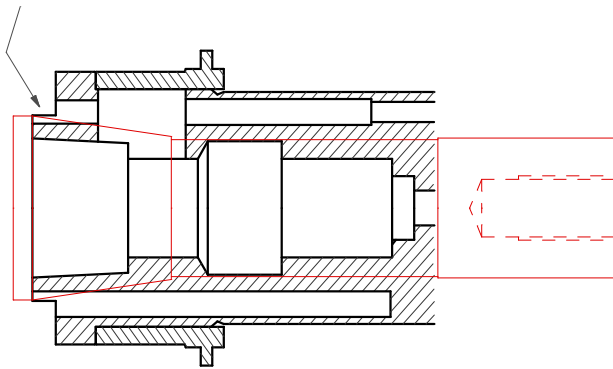
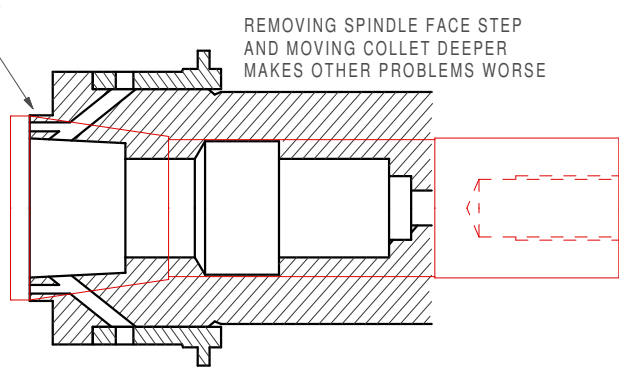

SPINDLE WITH R8 COLLET