

NOT ENOUGH METAL LEFT FOR SUPPORT

REMOVING SPINDLE FACE STEP AND  
MOVING TOOLHOLDER DEEPER MAKES  
OTHER PROBLEMS WORSE

TAPER INTERSECTS PIN HOLES

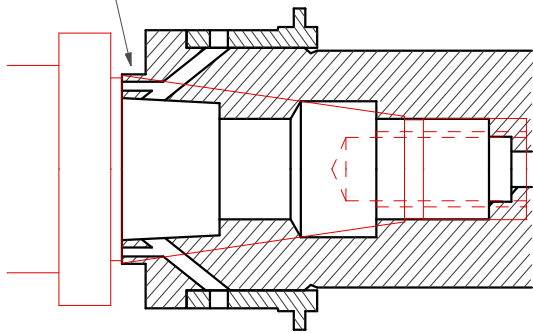

SECTION A-A

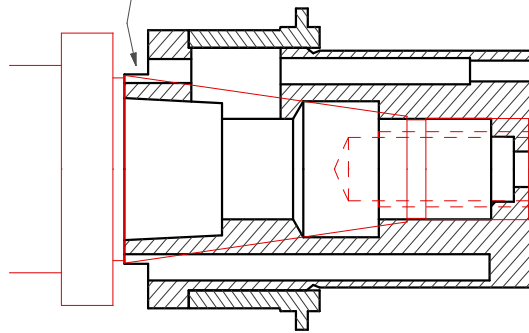

SECTION B-B

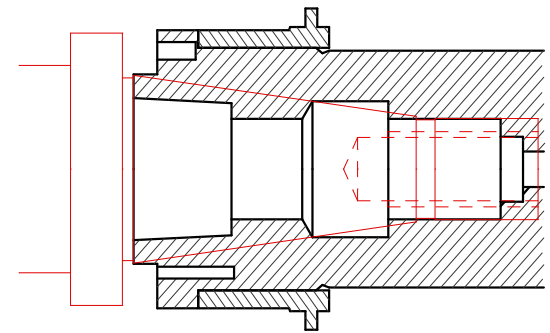

SECTION C-C

SPINDLE WITH NMTB 30 TOOLHOLDER